

# READ AND SAVE THESE INSTRUCTIONS

## ThinAir® HAND DRYER

MODELS: TA - ABS SB



# INSTALLATION AND OWNER'S MANUAL

## CONTENTS OF BOX



**1** Hand Dryer

**2** Tamper-Proof Wrench Knockout Gasket

**3** Installation and Owner's Manual

## MODEL INFO

Dryer Model

Serial Number

Date Of Purchase

120V

8 Amp

208–240V

4 Amp

230V

3.9 Amp

## 5-YEAR LIMITED WARRANTY (U.S. Only)

1. This product is warranted to be free of manufacturing defects for five (5) years (one [1] year on Pre-Filter) from the date of shipment from the Manufacturer's factory at 357 Chestnut St., East Longmeadow, Massachusetts 01028. This warranty explicitly excludes normal wear and tear on the Filter or Pre-Filter, as well as faulty installation, accident, misuse or vandalism.

In the event of a breach of the warranty described above, the Owner shall have either one of the following remedies:

a. The Owner shall return the defective product to the Manufacturer, postage prepaid, and the Manufacturer shall repair said product within a reasonable time and free of charge, provided that said product is returned within the stated period above from the date of original shipment from the Manufacturer's factory in East Longmeadow, Massachusetts; and, provided further that said defect is not due to faulty installation, accident, misuse, or vandalism; **or**

b. The Owner may notify the Manufacturer by telephone or in writing of the defect and, within a reasonable time, the Manufacturer shall send a suitable replacement part to remedy said defect, and Owner shall be charged for said part at the current price level. The Owner may return the defective part to the Manufacturer, postage prepaid, along with the serial number of the defective product and the Manufacturer will then issue to the Owner a full credit for the repair part, including outgoing postage (within the Continental U.S. only). Said remedy is available only within the stated period stated above from the date of original shipment of the product from the Manufacturer's factory in East Longmeadow, Massachusetts; and provided further that said defect is not due to faulty installation, accident, misuse, or vandalism.

2. Any implied warranties of merchantability or fitness for a particular purpose are hereby limited to the duration of the express written warranty contained in paragraph one (1); namely, five (5) years (one [1] year Pre-Filter) from the date of shipment from the Manufacturer's factory in East Longmeadow, Massachusetts.

3. If you reside outside of the U.S., please contact the distributor you purchased the ThinAir from for warranty support.

4. There are no other warranties and remedies except as contained herein. This warranty shall inure to the benefit of the Owners, Successors and Assigns.



EXCEL DRYER, INC 1.800.255.9235 EXCELDRYER.COM  
357 CHESTNUT STREET, EAST LONGMEADOW, MA 01028

ADMIN@EXCELDRYER.COM

3/2018

1

# READ AND SAVE THESE INSTRUCTIONS

## IMPORTANT SAFETY INSTRUCTIONS



**WARNING:** For proper electrical connections, check your local building codes. Your unit must be installed by a qualified, licensed electrician.

### PRE-INSTALLATION WIRING

- Check that the electrical supply corresponds to that shown on the rating sticker of unit. If the dryer is connected to any electrical supply other than that stated on the rating sticker of the unit, permanent damage or improper, unsafe operation of the unit may result.
- Make sure electricity is switched off at the main panel before installing, maintaining or cleaning this hand dryer. Dryer must be installed in accordance with current local wiring and building regulations.
- Do not wire this hand dryer into the lighting circuit. It must be protected by an independent circuit.
- Dryer is intended to be permanently connected to power supply, and must be properly grounded.

### SAFETY

- Troubleshooting and internal maintenance must be performed by qualified service personnel.
- Do not use any power wash equipment for cleaning on or near this unit.
- Do not use for drying hair.
- Do not obstruct air inlets or outlets.

## INSTALLATION INSTRUCTIONS

1. Disconnect the power source previously brought to the hand dryer location (see pre-installation wiring above).
2. Use the Tamper-Proof Wrench supplied and remove the Tamper-Proof Bolt on bottom of cover lifting upwards to remove cover from base plate.
3. If electrical wiring entry is to be made from the rear, remove the appropriate pre-formed knockout on the base plate. If entry is to be made from the side, knock out the preformed area on the right side of cover for your supply connection using knockout gasket provided. A rigid conduit must be used.
4. Select the appropriate mounting height for dryer (Table 1) and fastener, as recommended (Table 2). There should be no obstruction between the hand dryer and the floor. If mounting over a countertop, distance from counter to dryer must be 15" (381 mm) minimum.
5. Attach Base Plate at the four corners to smooth wall. Identify the voltage of your dryer from the rating sticker of the unit. Then connect to a dedicated branch circuit not exceeding 20 Amp.
6. Use one of 2 knockouts provided for service entry on back of Base Plate. If using surface wiring use knock out in right side of cover. Use Knockout Gasket supplied around conduit for water seal. See Mounting Details.
7. Secure electrical wiring to terminals as indicated by the schematic affixed to blower housing. An identified ground connection point is supplied on the Base Plate for your equipment ground wire. Dryers should be installed per local code requirements.
8. Carefully replace Cover by inserting top of cover over bracket and tilting downward. Use Tamper-Proof Bolt previously removed in step 2.
9. Restore power and test for proper operation. In multiple installations, make sure the serial number marked on the inside matches the cover number.
10. Return Tamper-Proof Wrench to owner.

**CAUTION:** Do not use Base Plate as a guide when drilling. Make sure no pipe work (gas, water, air) or any electrical cables or wires are located directly behind the area to be drilled.

### TABLE 1

#### 1 SUGGESTED MOUNTING HEIGHT from floor to bottom of dryer:

Men	45" (114 cm)
Women	43" (109 cm)
Teenagers	41" (104 cm)
Small Children	35" (89 cm)
Accessible	37" (94 cm)

### TABLE 2

#### 2 MOUNTING HARDWARE Recommended Fastener (not supplied):

Masonry Wall	½" Expansion Sleeve with ¼" Lag Bolt
Hollow Wall	¼" Wing Type Toggle Bolt
Wooden Wall	¼" Lag Screw With Washer



# READ AND SAVE THESE INSTRUCTIONS



**WARNING: TO REDUCE THE RISK OF FIRE, ELECTRIC SHOCK OR INJURY TO PERSONS, OBSERVE THE FOLLOWING:**

- A. Use this unit only in the manner intended by the manufacturer.
- B. Before servicing or cleaning unit, switch power off at service panel and lock the service disconnecting means to prevent power from being switched on accidentally. When the service disconnecting means cannot be locked, securely fasten a prominent warning device, such as a tag, to the service panel.

## MOUNTING DETAILS

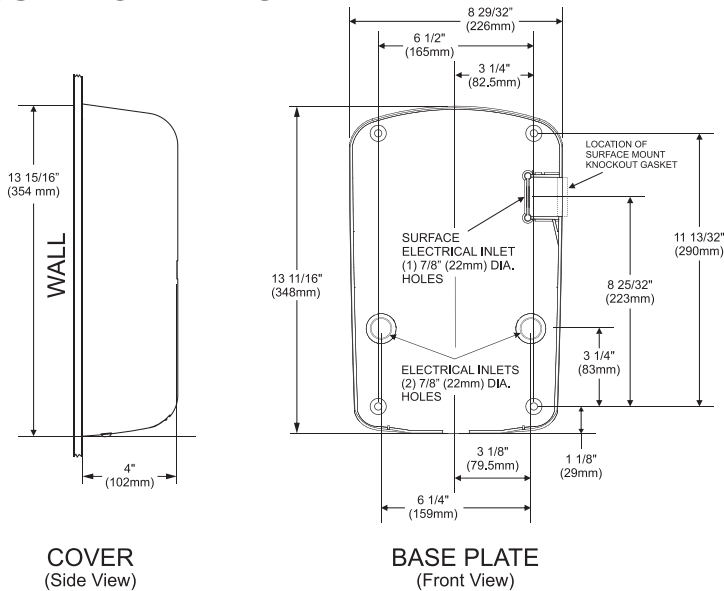

## CLEANING / MAINTENANCE

- OUTSIDE:** Gently wash Cover (including air inlet holes) using a soft cloth or sponge and a mild soap or detergent with lukewarm water to loosen dirt and grime.
- INSIDE:** Excel recommends inspecting the inside of the dryer and cleaning as required at least once per year, or if performance diminishes. Heavier usage, or an environment that contains excessive lint, dust or other particles, requires more frequent cleaning. Lint on the air inlet, the Pre-Filter, or other internal parts of dryer will reduce efficiency and shorten the life of the working parts.
- TO CLEAN:** Shut off power to dryer at service connection. Uses the Tamper-Proof Wrench supplied and remove the Tamper-Proof Bolt on bottom of cover lifting upwards to remove cover from base plate. Gently clean all parts using a small, soft brush. Unclip the Pre-Filter, rinse with water and dry. Re-install.

## TROUBLESHOOTING

### Dryer does not turn on

1. Check power to the unit and connections. Verify dryer is receiving voltage at Terminal Block.
2. Check RED service LED light for the following:  
**Light is ON** – Place hands under Sensor. If light stays on, then replace Sensor. If light goes off, check to make sure wiring is correct. If OK, check wire connecting to Motor. If both are OK, replace Motor.

**Light is OFF** – Check for loose, disconnected or improper wiring (See wiring schematic inside dryer Cover), or replace Control Assembly.

**Light is FLASHING** – See error codes in CODE chart.

**SENSOR RANGE ADJUSTMENT:** If dryer will not turn on, stays on, or stops working, it may be mounted too close to a counter or object and has gone into lockout. If relocating appliance is not possible, adjust the range of the Sensor. Turn off power to dryer then turn the range adjustment on the Control Assembly counterclockwise towards L (-) low to decrease Sensor range.

### Dryer does not shut off

1. May be mounted too close to a counter or object (adjust Sensor range).
2. Check for loose, disconnected or improper wiring (Refer to wiring schematic affixed to blower housing).
3. Replace Control Assembly.

### Dryer does not always turn on, or turns on by itself

1. May be mounted too close to counter or object (adjust Sensor range).
2. Check for foreign material on Optical Sensor next to Air Outlet.
3. Check for loose wires on Control Assembly.
4. Replace Control Assembly.

### Dryer heats up but no air comes out

1. Check wire connection to Motor.
2. Replace Motor.

### Dryer blows only cold air

1. Check heat setting on control.
2. Check for loose connections to Heating Element.
3. Replace Heating Element.

### Dryer has a loss of air volume

1. Check motor speed setting on control.
2. Check for slow running Motor or burning smell. If so, replace Motor.
3. Check Pre-Filter for lint buildup. Clean by removing Pre-Filter and rinse in warm water then dry Pre-Filter before reinstalling.



# READ AND SAVE THESE INSTRUCTIONS

## TROUBLESHOOTING (Continued)

### CODE CHART

Codes are displayed by flashing the red LED in the sensor behind air outlet. Normal operation will be indicated by the red LED being on when not drying and off when hands are under the sensor.

#### Dryer Maintenance Codes

1 Short / 1 Long flash	Clogged Pre-Filter	Clean Pre-Filter	Dryer will still run
2 Short / 1 Long flash	In lockout mode	Clear obstruction	Dryer stops until obstruction cleared

#### Motor Problem Codes

1 Long / 3 short flashes	Motor over current	Replace motor	Dryer will stop
1 Long / 4 short flashes	Motor under current	Replace motor	Dryer will stop

#### Heater Problem Codes

2 Long / 3 short flashes	Shorted or incorrect heater	Replace heater	Dryer will stop
2 Long / 4 short flashes	Open/broken heater	Replace heater	Dryer will still run

#### Voltage Problem Codes

3 Long / 3 short flashes	Main panel over voltage	Check incoming voltage	Dryer will stop
3 Long / 4 short flashes	Main panel under voltage	Check incoming voltage	Dryer will stop

If problem cannot be resolved with the above, please call the manufacturer at 1-800-255-9235 and one of our trained technicians will be happy to assist you.

### PARTS LIST

Ref. No.	Description
TA-1	Cover (includes nameplate)
TA-2	Tamper-Proof Bolt
TA-3	Tamper-Proof Wrench
TA-4	Knockout Gasket
TA-5	Bracket Cover Hook
TA-6	Nozzle
TA-7	Optic Bracket
TA-8	Optic Assembly
TA-9	Finger Guard
TA-10	Heating Element Assembly
TA-11	Muffler Housing (output)
TA-12	Muffler Foam (output)
TA-13	Motor Gasket Ring
TA-14	Clamshell Upper
TA-15	Bracket Cover
TA-16	Control Assembly
TA-17	Motor
TA-18	Motor Gasket
TA-19	Pre-filter (includes screen)
TA-20	Muffler Foam (input)
TA-21	Muffler Housing (input)
TA-22	Clamshell (lower)
TA-23	Base Plate
TA-24	Nameplate
TA-25	Tube (pressure)
TA-26	Terminal Block

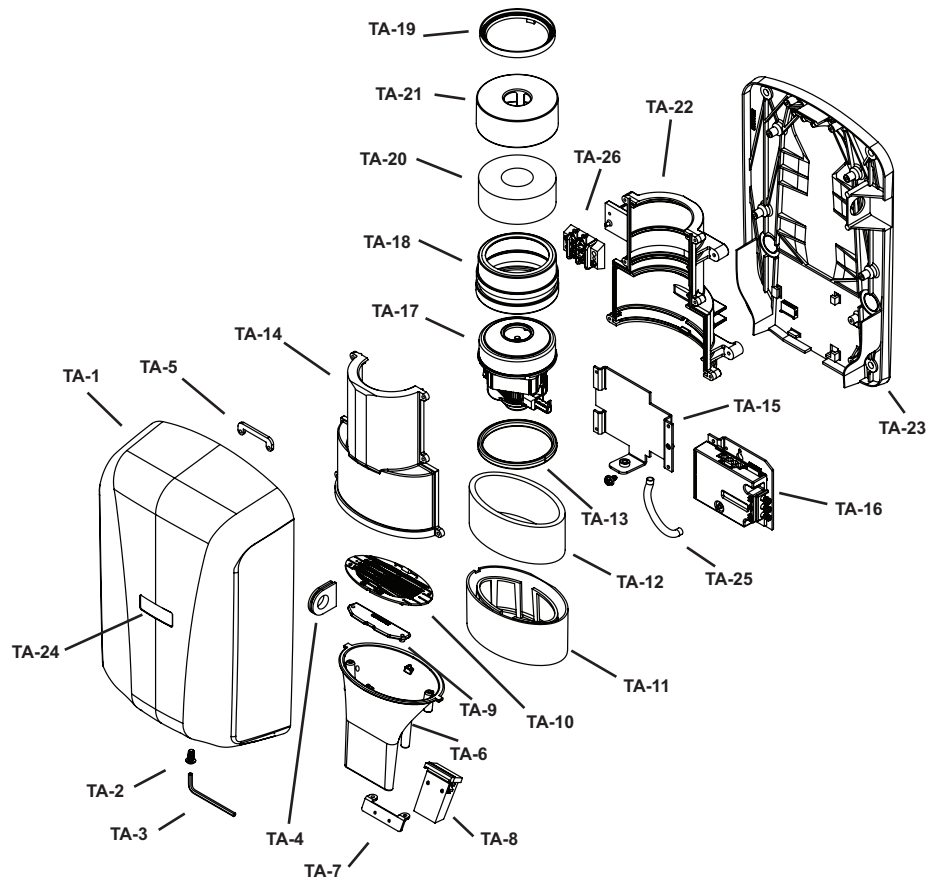

# TIME TO THROW IN THE TOWEL®

EXCEL DRYER INC • 1.800.255.9235 • EXCELDRYER.COM

MARCH 2018

18TAM0343